



HOW TO LAY PAVERS

WHAT YOU WILL NEED

- Two 40 mm screed rails (2 pieces of pipe or timber 40 mm thick and 2 m – 3 m long)
- One screeding board (a flat, straight piece of timber or aluminium 2.5 m long)
- ANL paving blend 1 m³ will cover approx. 20 m² laid 40 mm thick
- Roadbase for driveways or pathways available from ANL
- Vibrating Plate, compactor, with rubber base
- String line and pegs
- Edge restraints
- Rubber mallet and a piece of timber
- String line level, water level or spirit level
- Broom
- Hammer
- Cutting equipment – brick bolster/paving splitter/diamond saw.

SITE PREPARATION

Select the desired finished surface level. Drive stakes into the ground at the extremities of the proposed paved area. Run string lines between them at the finished surface level using a string level, water level or spirit level.

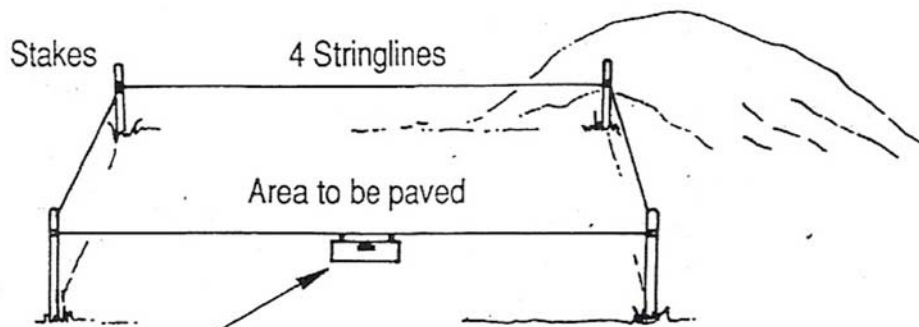

(Set all stringline levels first to establish a datum, then adjust for drainage falls. Slope paving away from house.)

Once the paving level is established, adjust the string lines to allow for surface drainage – minimum fall 1:60.

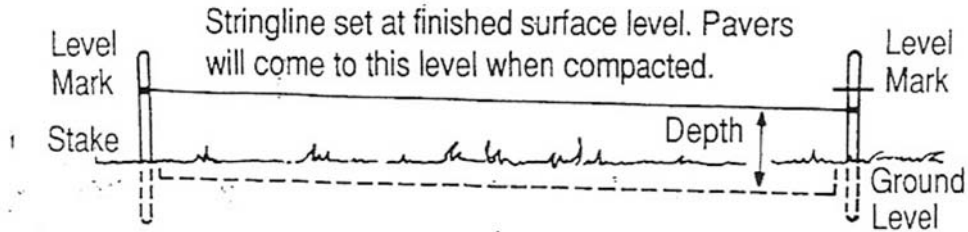

Finished paving must be below the damp proof course level of the building.
 Paving must always slope away from the building. Prepared ground must be even and parallel to finished paver surface level.

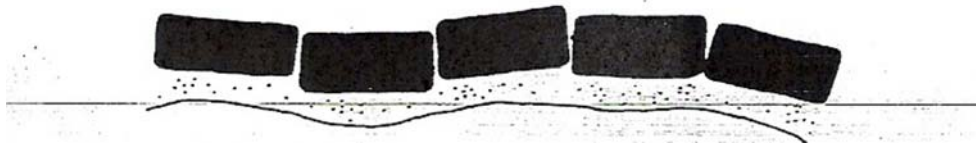

(NB: An uneven base will give an uneven paver surface.)

Any soft or wet spots must be removed and replaced with roadbase – in some cases stabilised with cement and well compacted.

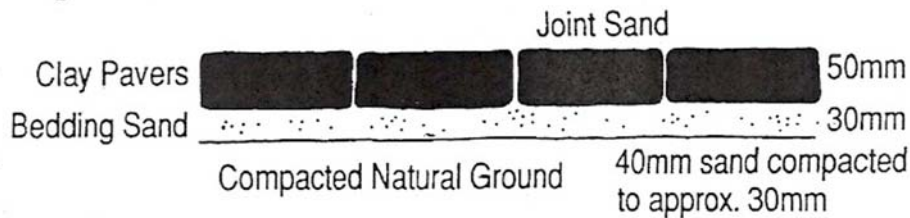

DRIVEWAYS

Spread roadbase to required area – compact with a vibrating plate compactor – wetting the roadbase before compacting.

Vibrate until fines rise to the surface to give a smooth fine finish.

The thickness required is dependent on the type of soil – poor soils (silt/plastic clays) may need 100 mm – 125 mm thickness.

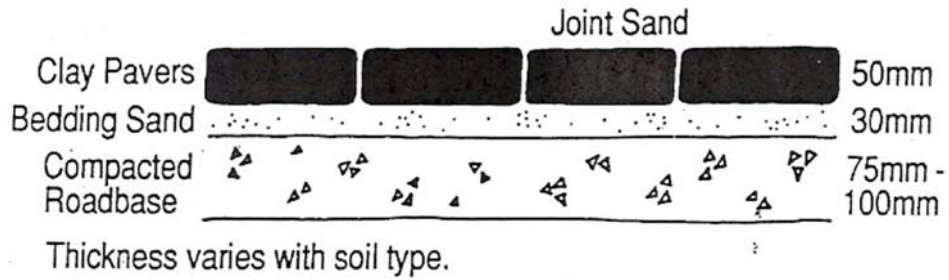

SPREADING THE SAND

Sand is not a leveling medium, thickness must be consistent over the whole job, otherwise uneven settlement will take place. Protect sand if not used immediately by covering with a waterproof cover to retain moisture content.

Place screeding rails in position ensuring top of rails are at the correct level. Spread a layer of the bedding sand over the rails – do not walk on the sand so as to avoid possible pre-compaction.

With assistance from a helper, draw the screeding board over the screeding rails to obtain a consistent 40 mm thickness. This operation must be conducted with each person working from the outside the screeding rails to again avoid pre-compaction.

Remove the screed rails, fill the indentions with loose sand to the level of the surrounding screeded sand. Do not walk on the sand after it has been screeded.



Excess sand not yet screeded spread loosely with shovel.

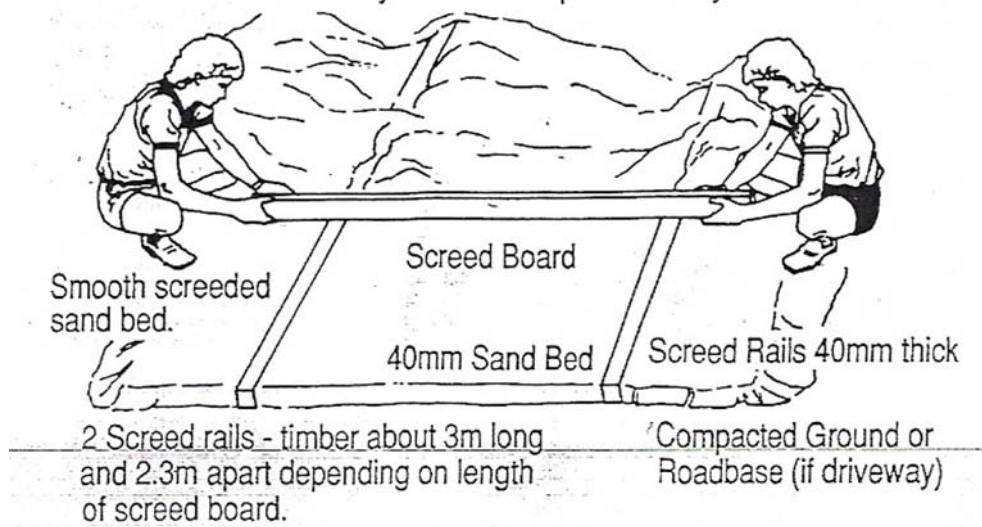

LAYING THE PAVERS

If laying on a slope, always commence laying from the bottom. Herringbone is the recommended pattern for driveways.

SETTING OUT

Clay pavers, being made of natural material, vary slightly in size. If you do not allow for this size variation, the pattern of the pavement may not stay in line. The best way to regulate the pattern is to use a grid of string lines spaced at exact intervals. It sounds complicated, but it's really very simple and will save work in the long run.

1. First you will need to determine the average width of your pavers. Select 30 pavers at random, place them tightly side by side and measure their overall width. Divide this figure by 30 to get an average width.

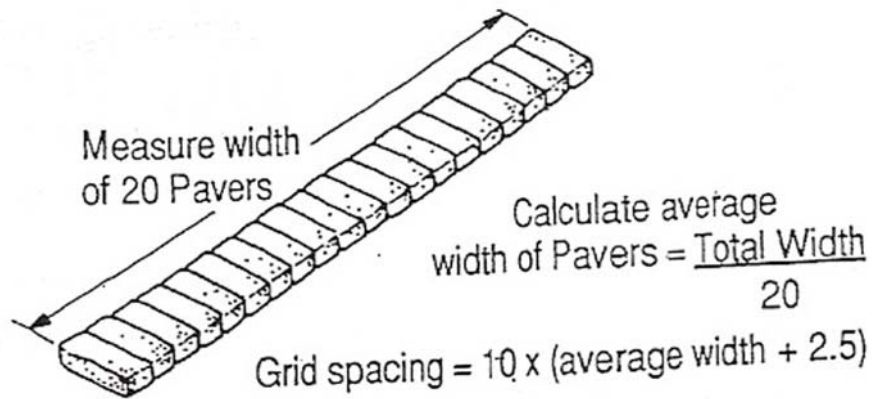

2. Add 2.5 mm to this average width (to allow for the joint between the pavers) multiply by 10 (for 10 pavers). This is the spacing for the grid of string lines.

For example, if the average paver width was 112.5 mm, the grid spacing would be 1150 (115 mm x 10). To set out an area with 90% and maintain the squareness of the job use the ratio 3:4:5.

Always blend pavers off two or three pallets to obtain a full blending of colour. Always leave a 2 mm -4mm gap between pavers – do not allow pavers to touch as this will cause chipping. Work to a stringline as the job progresses and adjust paving with a screwdriver or trowel.

At the end of each day cut all infill pavers that are necessary, install and compact the laid area. Do not compact closer than 1m to the working face.

Most bond patterns require some cutting of the pavers. Cutting pavers by hand is not difficult. You need a sharp bolster and a heavy club hammer. (Pavers may also be cut with a hydraulic cutter or a diamond saw.)

- a) Line up the bolster on the top of the paver and hit with the club hammer to score the face
- b) Repeat this for the other three sides.
- c) Place the bolster over the scored mark and hit it firmly with the bolster to crack the paver.
- d) Clean the face of the best half.

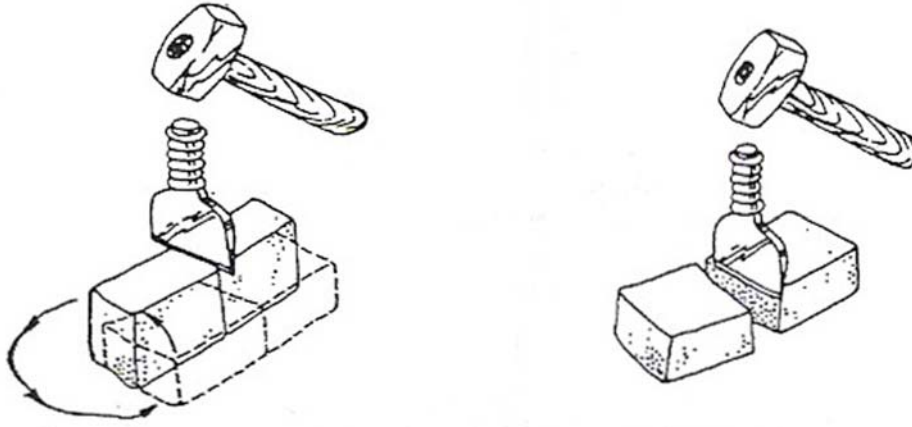

Patterns may be utilized at an angle and designs can be enhanced by a header course.

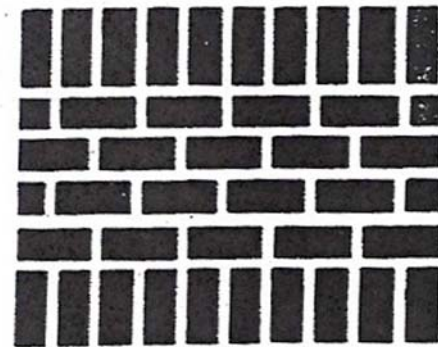
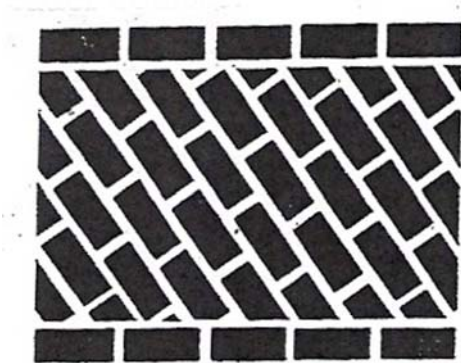

EDGE RESTRAINTS

Finish edge restraints 10 mm below un-compacted pavers to allow for compaction.

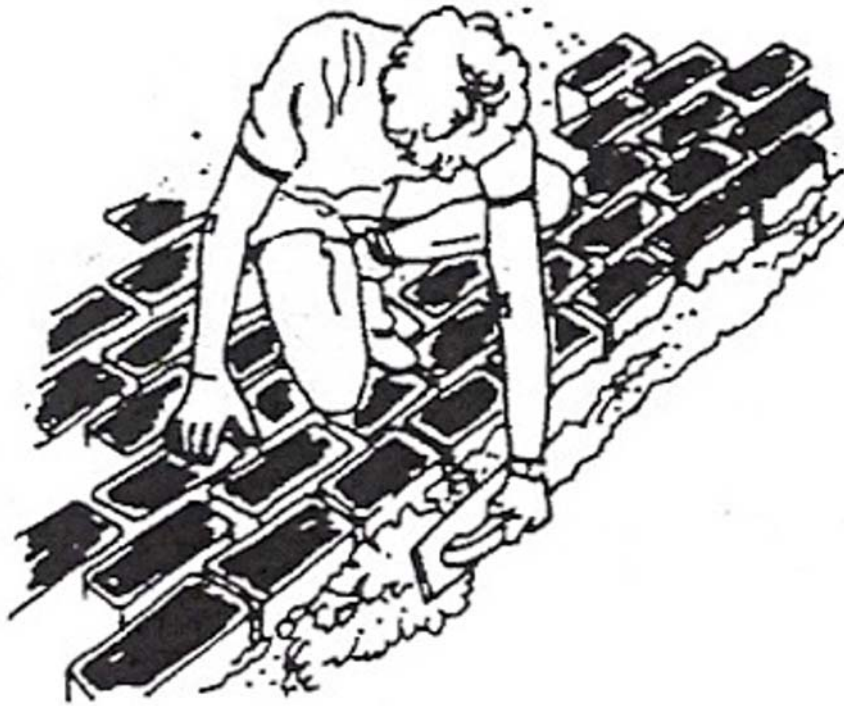

Edge restraints are necessary to retain and restrain the paving units and sand. Otherwise, paving failure may occur.

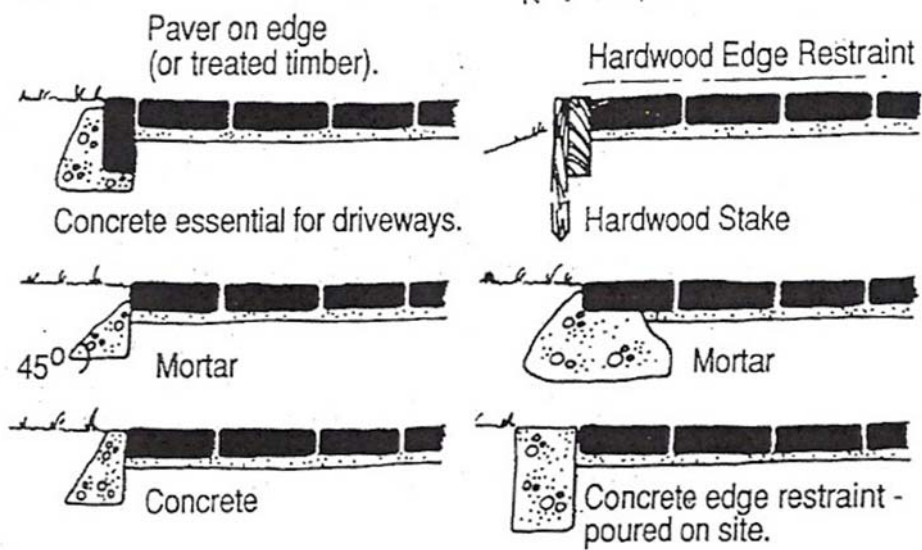

COMPACTING THE PAVERS



On small jobs a rubber mallet and a piece of timber will aid compaction. For driveways and larger paving jobs use a mechanical plate vibrator. Use plywood under the vibrator to prevent paver chipping and damage.

After the initial pass with the vibrator, spread the joint sand over the pavers, to ensure “lock up” of pavers. After the second pass of the vibrator, the joints may have to be “topped up” by sweeping the sand into the joints.

As previously noted, at the end of the day vibrate the paver and place joint filling to stop any damage to new paving overnight due to wet weather.

IMPORTANT NOTES

1. Do not mix cement with joint filling sand.
2. Do not hose sand into joints.
3. Do not clean pavers with hydrochloric acid
4. Use a vibrator with a rubber plate or use sheets of plywood to protect pavers during compaction.
5. Efflorescence – Water soluble salts occur in natural products such as clay, crushed rock and soil. Through capillary action these salts can be drawn to the surface of the paver resulting in a white deposit. These salts have no affect on the pavers, only the appearance. These deposits will disappear in time, but the process can be accelerated by brushing these deposits off the pavers with a stiff bristled broom.
6. A gap of 2 mm-4 mm must be installed between all pavers to obtain “lock up” of pavers – i.e. the ability to take loading (e.g. cars), to take up the inherent size variation which occurs in a natural clay product, and allow for paving growth. Clay products “grow” slightly over a period of time.
7. On large areas of paving it may be necessary to install expansion gaps. Strongly recommended around pools.